

ATLAS

PRECISION POSITIONING DEVICE



High-performance, high-precision robust pedestal positioner for orienting heavy payloads in harsh-environment deployments.

The ATLAS pedestal unit represents the next generation in positioning devices. Its stable base provides an ideal platform for an RF dish, long range camera, or acoustic device. The 19-bit optical encoder allows for ultimate precision and repeatability.

ROS has been manufacturing an array of harsh environment cameras, lights, positioners, and specialized systems designed for oceanographic, nuclear, industrial, and military applications for over 30 years.

Robust platform for RF antennas, long distance cameras, or other heavy payloads

300 pound payload capacity (136 Kg)

Slip ring and optional RF rotary joint allow continuous pan-axis rotation

Rugged, submersible housing designed for harsh environments

High-precision, 0.001° repeatability



ATLAS - Precision Position Pan & Tilt Unit

ELECTRICAL

Operating Voltage Range	18-28VDC, 24VDC Typical
Operating Power Range	10-92 Watts/Axis (Depending on Load and Settings) (See Electrical Power curves for details)
Minimum Power Consumption	5 Watts/Axis with Idle with brake OFF
Active Braking Power Range	Adjustable 5-35 Watts/Axis (See Electrical Power Curves for details)
Motor Running Current	0-100%, User adjustable
Motor Acceleration Current	0-100%, User Adjustable
Position Feedback Type	19-bit Optical encoder
Software Limits	2 limits per axis, User Adjustable
Acceleration & Deceleration	0.001- 100 Deg/s ² , User Adjustable
Angular Velocity	0.001-40.000 Deg/s, in increments of 0.001 Deg/s
Position Control	Goto functions, integrated acceleration/deceleration ramps
Slip/Stall Detection	Enabled or Disabled
Electronics temperature protection	Enabled
Control & Feedback Interface	Full Duplex 4-Wire RS-485
Communication Baud Rate	9.6K (Optional Faster Rates)
Communication Protocol	ROS Document:27-03268
Networkability	Multiple Pan & Tilts
Slip Ring Circuits (Pan Axis)	13 user contacts rated to 5A each
(Optional) Rotary Joint Frequency	18 GHz

MECHANICAL

Maximum Payload	300 lbs. (136 Kg)
Rated Torque	See Mechanical Power Curves
Minimum Static Brake Torque (Active Brake OFF)	10 lb.ft. (13.5 Nm)
Active Brake Torque	10-160 lb.ft., User Adjustable (13.5 - 216 Nm)
Maximum Angular Velocity	40 Deg/s
Maximum Acceleration/Deceleration	100 Deg/s ²
Feedback Resolution (repeatable)	0.05 Deg
Repeatability (Assuming no Slip/Stall Condition)	0.001 Deg
Scan Range (Pan/Tilt)	Continuous / Continuous
Duty cycle	100 % *
Housing Material	Natural Anodized 6061-T6 Aluminum
Height	Variable, 29.5" Standard (75 cm)
Width	Variable, 27.80" Standard (70 cm)
Weight	Variable (size dependent), 91 Lbs Standard (41 Kg)
Connectors	Customer Specified
Housing Mounting	12 x 3/8-16
Equipment Mounting	Customer Specified

ENVIRONMENTAL

Depth	5 m
Altitude	25,000 Meters
Operating Temperature	0 to +50° C **
Storage Temperature	0 to +50° C

* Depends on load, external temperature, and settings

** Can work at higher temperature under specified conditions



5618 Copley Drive
San Diego, CA 92111 USA
Tel (858) 565-8500
Fax (858) 565-8808
East Coast Office (804) 754-3936

www.rosys.com
sales@rosys.com

ATLAS - Precision Position Pan & Tilt Unit

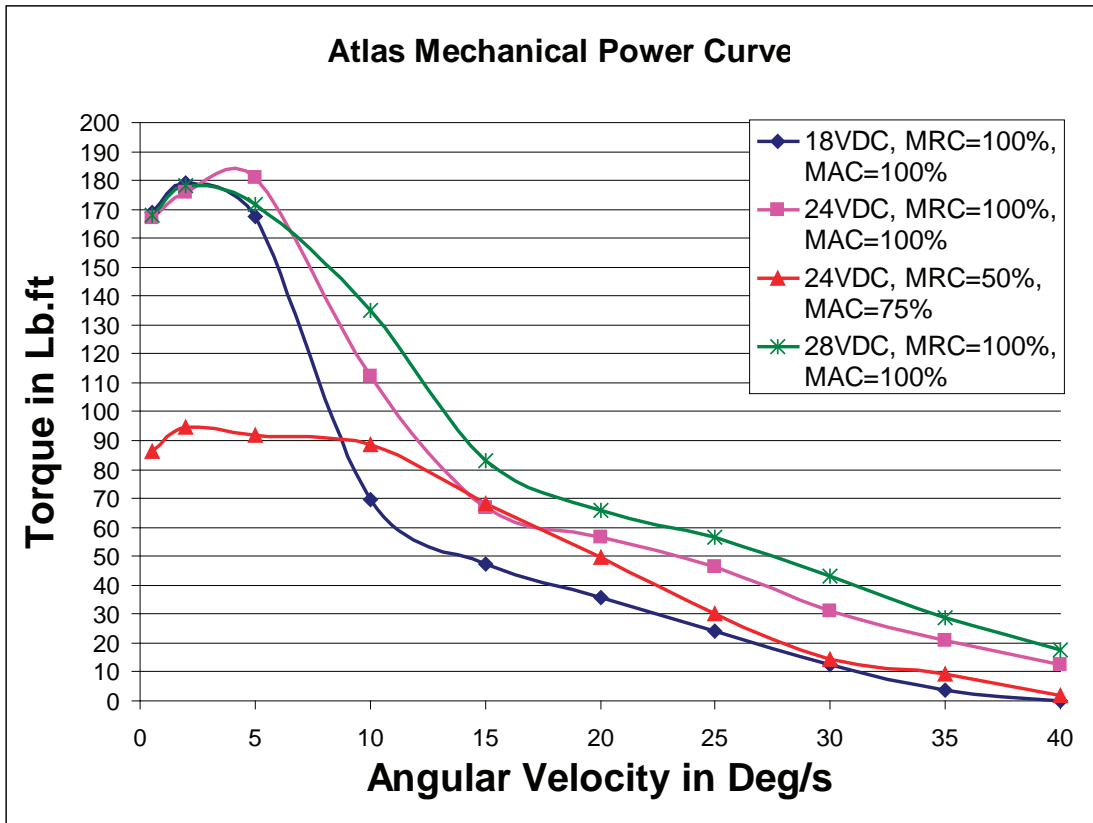
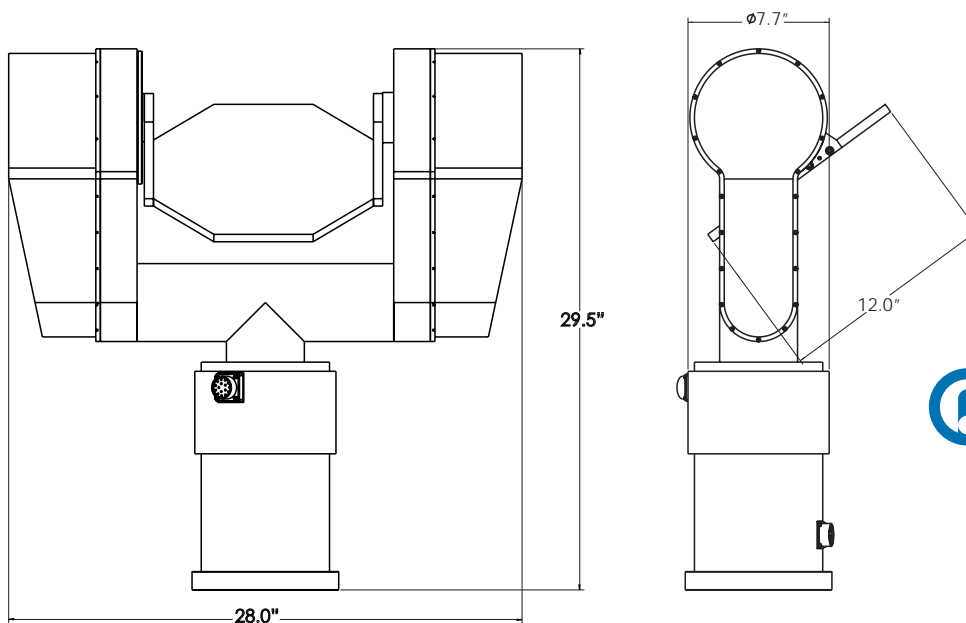

Figure 1: Atlas Mechanical Power Curve

NOTE: MAC= Motor Acceleration Current (%)
MRC= Motor Running Current (%)



5618 Copley Drive
San Diego, CA 92111 USA
Tel (858) 565-8500
Fax (858) 565-8808
East Coast Office (804) 754-3936

www.rosys.com
sales@rosys.com

ATLAS - Precision Position Pan & Tilt Unit

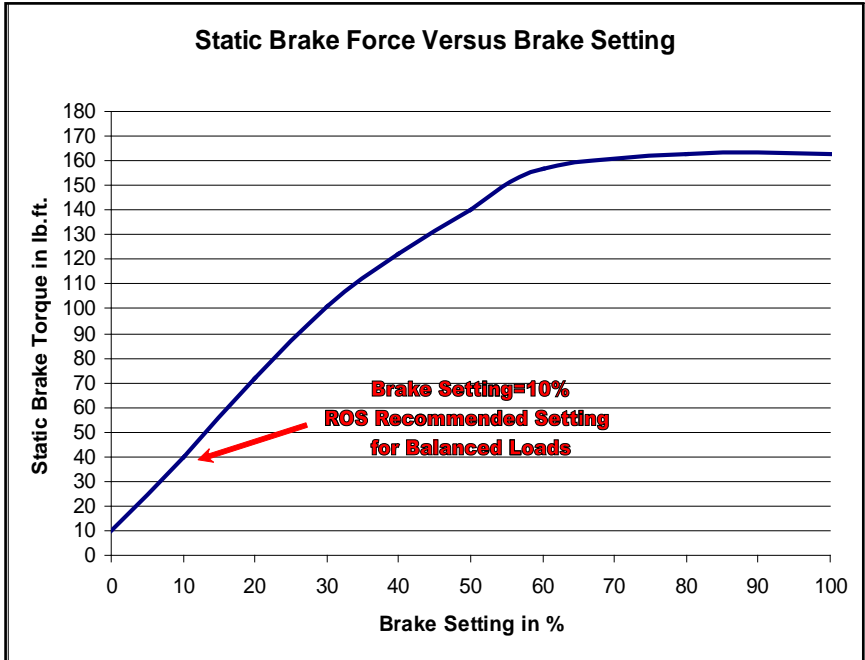

Conversion from
lb.ft. to Nm:
Nm ~ lb.ft. x 1.35

Figure 2: Static Brake Torque versus Brake Setting

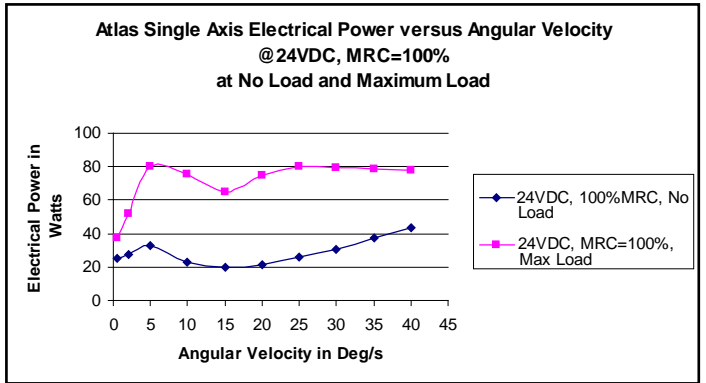
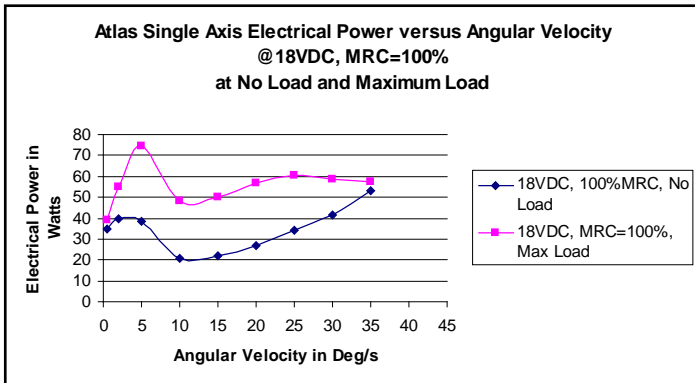

Figure 3: Electrical Power versus Angular Velocity in no load, and Maximum Load Conditions

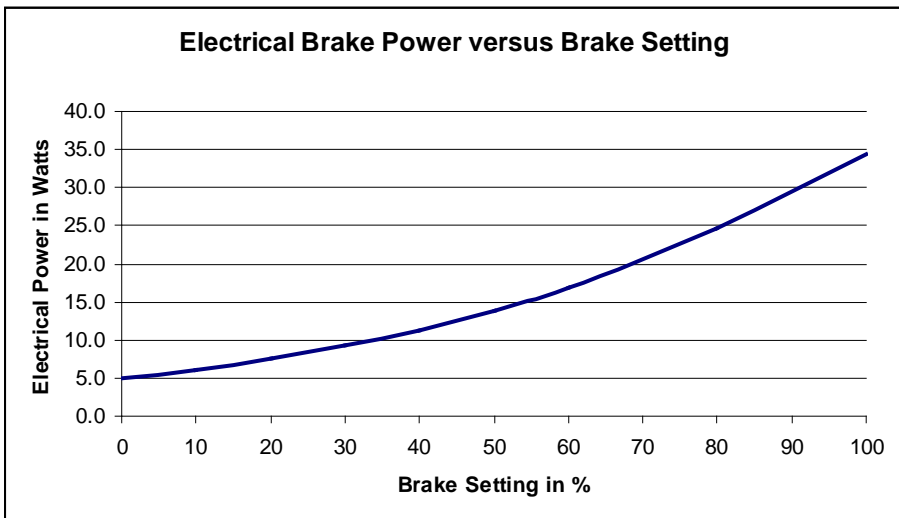

Figure 4: Electrical Brake Power versus Brake Setting



5618 Copley Drive
San Diego, CA 92111 USA
Tel (858) 565-8500
Fax (858) 565-8808
East Coast Office (804) 754-3936

www.rosys.com
sales@rosys.com